

MOTORI PENTAVALENTI ACCESSORI

VENTOLE IN ALLUMINIO

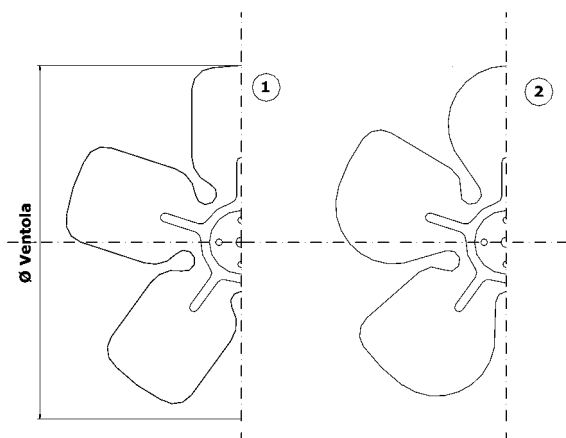

Ø	ANGOLAZIONE mm	FIG. PALA	VERSIONE	COD	€
154	26°	1	ASP.	21115004	3,00
			PREM.	21115005	3,00
172	26°	2	ASP.	21117004	3,00
			PREM.	21117005	3,00
200	28°	2	ASP.	21120004	3,00
			PREM.	21120005	3,00
230	26°	2	ASP.	21123004	3,00
			PREM.	21123005	3,00
254	28°	2	ASP.	21125004	4,00
			PREM.	21125005	4,00
300	22°	2	ASP.	21130004	8,00
			PREM.	21130005	8,00
350	19°	2	ASP.	21135004	15,00

GRIGLIE

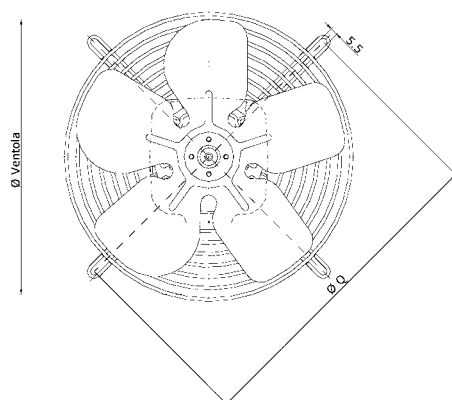

Ø Ventola	Ø Q mm	COD	€
154	190	41015417	9,00
172	208	41017217	9,00
200	235	41020017	9,00
230	294	41023017	9,00
254	290	41025417	15,10
300	344	41030017	17,80
350	410	41035017	19,15

BOCCAGLI

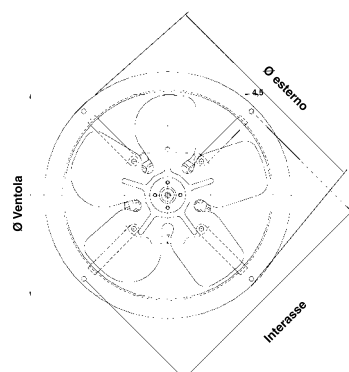

Ø Ventola	Ø Int. mm	Ø Est. mm	Interasse	COD	€
154	162	200	190	40115048	12,00
172	180	222	206	40117048	14,10
200	212	245	235	40120048	9,00
230	240	275	265	40123048	14,88
254	262	300	290	40125048	17,68
300	307	350	343	40130048	15,00