

ESTRATTORI DA MURO

RS 80 A/C

ÖSTBERG
HEALTHY INDOOR CLIMATE
WITH ENERGY EFFICIENT VENTILATION

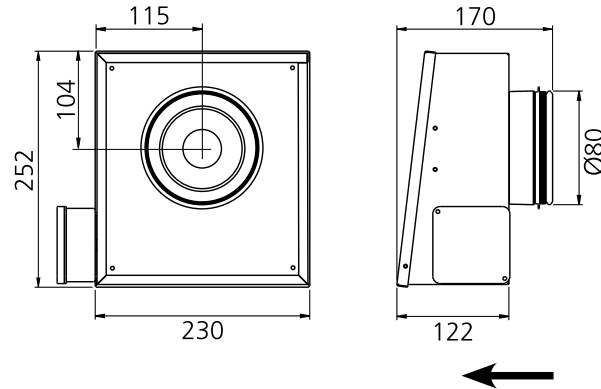

DATI TECNICI

MOD.	V/Hz	A	W	rpm	kg	μ F	CLASSE ISOLAM. motore	PROTEZ. motore	COD	€
RS 80 A	230/50-60	0,20	45	1850	3,4	3	F	IP 44	0411929	241,50

PRESSIONE/FLUSSO

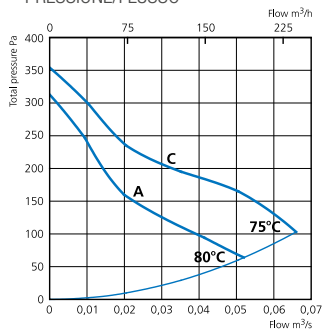

DATI ACUSTICI

	L_{pA}	L_{WA} tot dB (A)	63	125	250	500	1K	2K	4K	8K
RS80 A, 30 L/s 125 Pa										
AMBIENTE	57	64	31	39	52	59	62	58	51	43
INGRESSO		66	57	58	60	61	59	55	50	42
RS80 C, 35 L/s 195 Pa										
AMBIENTE	63	70	36	43	56	64	67	63	58	49
INGRESSO		72	61	63	66	67	66	61	56	50

POTENZA/FLUSSO

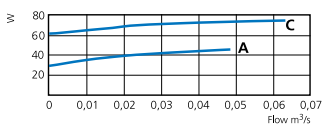

TENUTE

POMPE

VENTILATORI

MOTORI

ISOLANTI

ATTREZZATURE

RICAMBI MOTORI

RICAMBI UTENSILI

INTERRUTTORI