

ELECTRIC PUMPS BC-ST SERIES

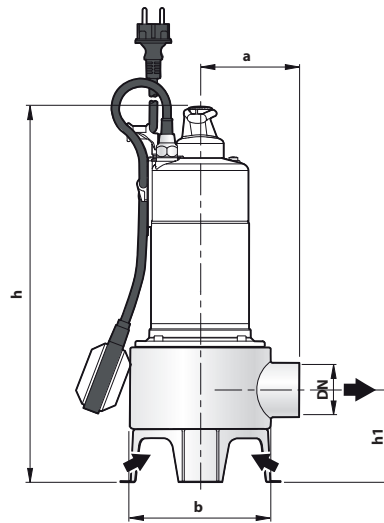

DOUBLE CHANNEL submersible

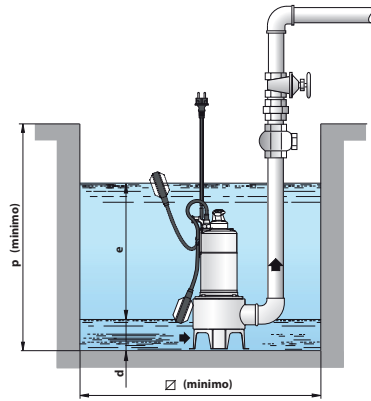

Model	KW	Hp	Delivery head intake	Power cable m	CODE	€
Single-phase	0.75	1	2"	5	P-BCm 10/50-ST	380.00
Three-phase	0.75	1	2"	5	P-BC 10/50-ST	395.00
Three-phase	1.1	1.5	2"	10	P-BC 15/50-ST	415.00

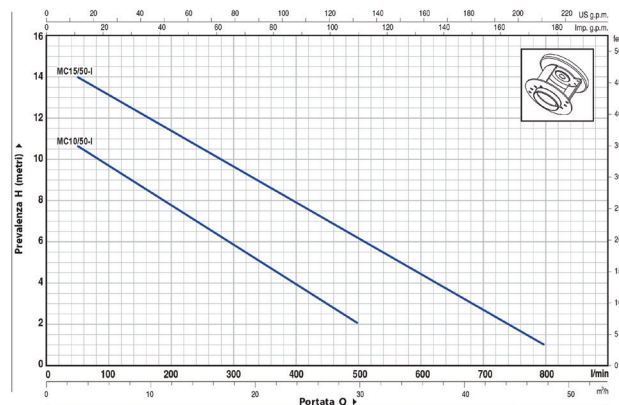

PERFORMANCE CURVES AND DATA 50 Hz n=2900 1/min

Pumped liquid: sewage water drainage
Use: domestic, civil, industrial
Type: submersible
Technique: double channel

PERFORMANCE RANGE

- Flow rate up to 800 l/min (48 m³/h)
- Head up to 15 m

LIMITS OF USE

- Depth of use below the water level up to 5 m
- Temperature of the liquid up to +40 °C
- Passage of suspended solid objects up to Ø 50 mm
- For continuous service, minimum immersion up to 300 mm

N.B.: All models are also available with 10 m cable.

Prices valid at the time of printing of the catalogue, and subject to changes by the manufacturer. For up-to-date prices and applied discounts on the products listed on this page, please contact our sales office Tel. 02 89231200 - faet@faet.it - Fax 02 89231230