

# FAN COIL UNIT MOTORS DIRECTLY COUPLED

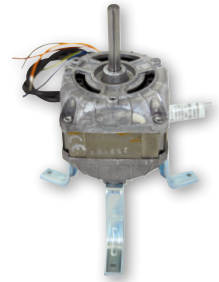

**CODE 0402408**  
MOTOR 83-2025/01

WHITE	Common
BROWN	1st Speed Max
BLACK	2nd Speed
BLUE	3rd Speed
RED	4th Speed
YELLOW	
GREEN	C
YELLOW-GREEN	

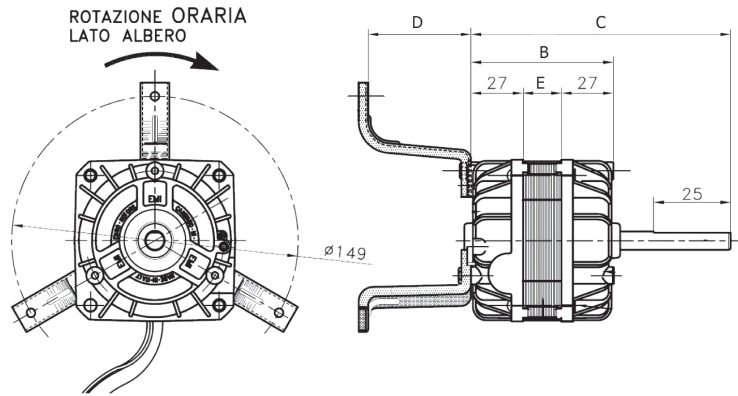

**CODE 0402409**  
MOTOR 83-2025/3

BLUE	Common
BROWN	1st Speed Max
BLACK	2nd Speed
GREY	3rd Speed
VIOLET	4th Speed
ORANGE	5th Speed
RED	6th Speed
YELLOW	
GREEN	C
YELLOW-GREEN	

V	HZ	A	W OUTPUT	W ABS.	N° SPEEDS	rpm	B	C	D	E	Ø	€	
230	50	0.46	25	100	4	1100	74	106	53.5	20	9.52	<b>0402408</b>	<b>120,00</b>
230	50	0.36	25	90	6	1100	71	106	53.5	20	9.52	<b>0402409</b>	<b>126,00</b>
230	50	0.48	28	64	4	1100	79	135	53.5	40	9.52	<b>0402410</b>	<b>120,00</b>

**CODE 0402410** MOTOR  
83M-2521/01

BLUE	Common
BROWN	1st Speed Max
BLACK	2nd Speed
ORANGE	3rd Speed
RED	4th Speed
YELLOW	
GREEN	C
YELLOW-GREEN	

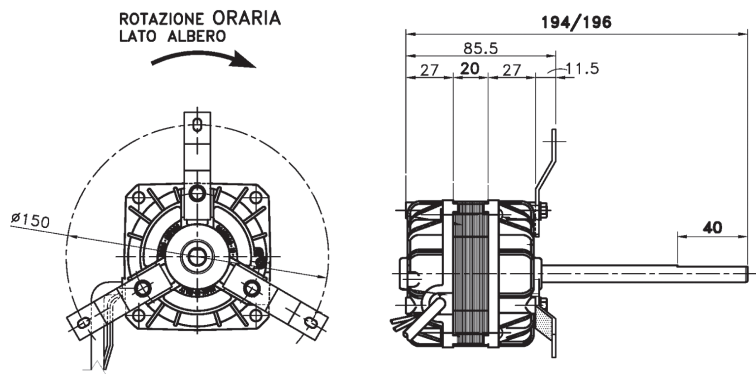

**CODE 0402411**  
MOTOR 83-2015/08

WHITE	Common
BLACK	1st Speed Max
BLUE	2nd Speed
RED	3rd Speed
YELLOW	
GREEN	C
YELLOW-GREEN	

V	Hz	A	W Output	W Ass.	N° Speeds	rpm	Ø Shaft	CODE	€
220/240	50	0.23	13	50	3	1100	9.52	<b>0402411</b>	<b>112,00</b>

DESCRIPTION:  
Spare motor for centrifugal fans installed mainly in fan coil ventilation units.