

WALL-MOUNTED EXTRACTORS

RS 100 A/C

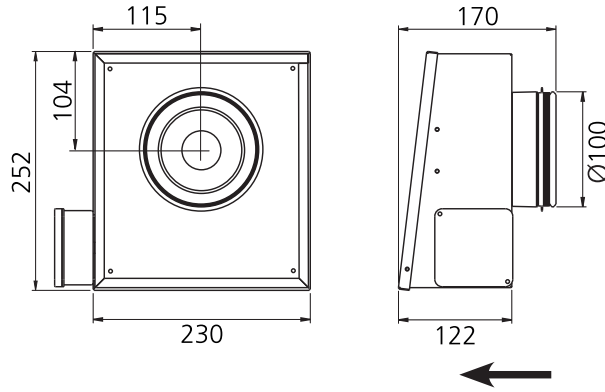

TECHNICAL DATA

MOD.	V/Hz	A	W	rpm	kg	µF	INSUL. CLASS motor	PROTEC. motor	CODE	€
RS 100 C	230/50-60	0,21	62	2490	3,4	2	F	IP 44	0411931	250,00

PRESSURE/FLOW

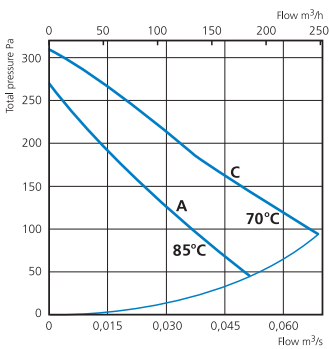

ACOUSTIC DATA

	L_{pA}	L_{wA} tot dB (A)	63	125	250	500	1K	2K	4K	8K
RS 100 A, 35 L/s 105 Pa										
AMBIENT	56	63	30	37	49	56	61	56	50	41
INTAKE		67	58	59	61	61	60	55	50	42
RS 100 C, 35 L/s 195 Pa										
AMBIENT	62	69	35	43	54	63	67	62	57	48
INTAKE		73	60	61	66	68	67	62	57	53

POWER/FLOW

