

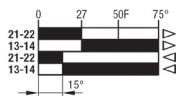

BENT LEVER WITH PLASTIC ROLLER

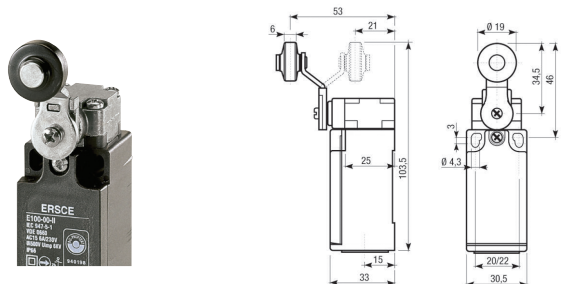

CONTACT ELEMENT	CODE	€/pc
1NO+1NC quick action 	00	E10000II

€/pc
17.40

VARIABLE LENGTH LEVER WITH PLASTIC ROLLER

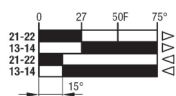
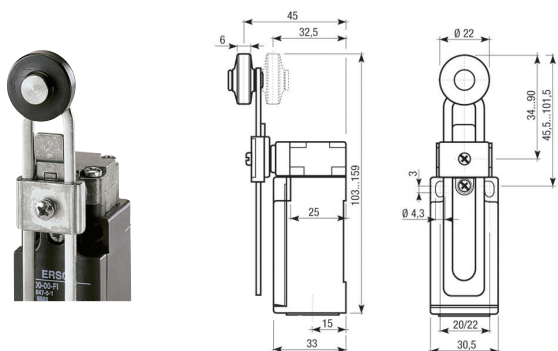

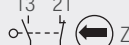
CONTACT ELEMENT	CODE	€/pc
1NO+1NC quick action 	00	E10000FI

€/pc
18.47

VARIABLE LENGTH LEVER WITH Ø50 PLASTIC ROLLER

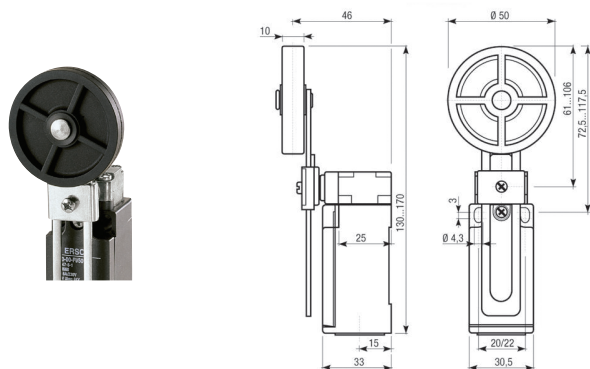

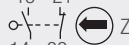
CONTACT ELEMENT	CODE	€/pc
1NO+1NC quick action 	00	E10000FI50

€/pc
21.98

WITH FLEXIBLE ROD

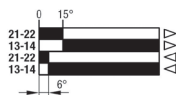
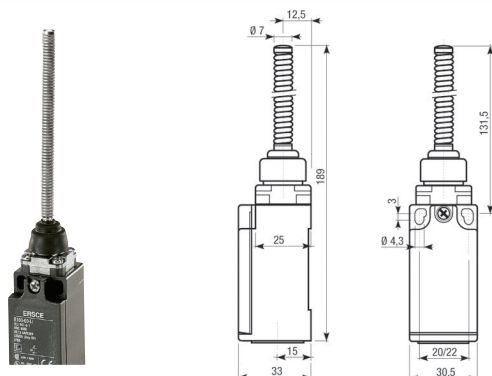

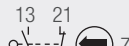
CONTACT ELEMENT	CODE	€/pc
1NO+1NC quick action 	00	E10000LI

€/pc
21.98

Two holes for fastening, with 20 and 22 mm distance between centres
 Compliant with standards IEC/EN 60947-1 IEC/EN 60947-5-1
 CERTIFICATIONS

UL file E72861  - CSA File 026716-0-000 



CABLE ENTRY
 1 cable entry on the bottom of the switch,
 with thread: Pg. 13.5
 M20 (on request)
 1/2" NPT (on request)
 PG11 (on request)

All products in the BREMAS ERSCE catalogue can be provided on request.